

LIGHTING TRACKS



 **MEKA**

www.meka.net

MEKA

Meka is a Finnish company whose business idea is to produce high-quality and competitive cable support systems for the various construction projects of our customers.

Meka cable support systems are manufactured from high quality raw materials. We operate on all levels based on the principles of sustainable development of the environment. All Meka products are technically tested and meet the given technical specifications.

Designing of Meka products is focused on easy installation facilitated by versatile installation components. This ensures the high quality and applicability of products even in the most demanding environments.

Using Meka's cable support systems is a modern way of electrifying different buildings and spaces easily and economically.

Meka has ISO 9001 Quality System Certificate which is valid for product development, manufacturing and marketing.

PRODUCT RANGE

Cable ladders

KS20, KS30 and KS35 cable ladders - made of hot galvanised metal sheet, coating thickness approx. 20 µm of zinc. Can be used in offices, shops, schools, hospitals, warehouses and industrial spaces (environment classification C1 and C2).

KS80, KSE80 and KSF80 – tube type cable ladders. Hot dip galvanised after manufacture, coating thickness approx. 60 µm of zinc. Can be used for industrial applications where high and concentrated load carrying capacity, lateral rigidity and a durable surface finishing are required. These include: industrial building sites, power plants, food, pharmaceutical and animal feed industry, humid areas and tunnels etc. industrial areas (environment classification C1, C2, C3 and C4).

RST and HST - stainless steel and acid-proof cable ladders can be used in chemical and wood processing industry as well as in other highly corrosive environments. Other places of use are places where hygiene is a vital factor, such as in dairies, slaughter-houses, other areas of food industry and pharmaceutical plants, tunnels etc.

PEX – tube type cable ladders. Hot dip galvanised after manufacture (coating thickness approx. 60 µm of zinc), powder painted and finally hardened in an oven. Can be used in industrial areas with high humidity and harsh atmosphere coastal or offshore areas (environment classification C5-I and C5-M).

Cable trays and lighting tracks

KRA, KRB, KRC and KRV - smooth and perforated cable trays with different height of border: 12, 40, 60, 80 and 110 mm.

MEK 70 and MEK 110 - lighting tracks with special groove for sliding nuts.

Cable trays and lighting tracks are made of hot galvanised sheet metal or hot galvanised and coil coated sheet metal. The standard colour in coil coated products is white (RAL 9010, NCS 0502-Y), other colours are available on request.

Cable trays KR and lighting tracks MEK are used in office buildings, business locations, shopping centres, schools and other public buildings in which the cable trays are an integral part of the interior (environment classification C1 and C2).

(Environment classifications according to SFS-EN ISO 12944-2 standard.)

Cable trunkings and socket poles

INSTAL cable trunkings and **INSTAL SP** socket poles are used in electrical installations where the design and appearance are an integral and important part of the interior.

Main applications are offices, public buildings, business locations, schools and hospitals.

INSTAL products are made of aluminium and painted white (RAL 9010) or grey (RAL 9006), or anodised, in which case they retain their natural metal tone. Products painted in other colours could be available on request. Nearly all possible mounting boxes can be used in connection with the INSTAL trunkings and socket poles, which mean that the fixtures suitable for any given environment can be chosen freely.



CORROSION CLASSIFICATION

The choice of surface treatment are made according to factors effecting the product in the surrounding environment, as specified in the SFS-EN ISO 12944-2 standard.

Corrosivity category	Examples of typical environments in a temperate climate (informative only)		Surface treatment required
	Exterior	Interior	
C1 very low		Heated buildings with clean atmospheres, e.g. offices, shops, schools, hotels.	Hot galvanised sheet metal, or plastic coated sheet metal.
C2 low	Atmospheres with low level of pollution. Mostly rural areas.	Unheated buildings where condensation may occur, e.g. warehouses, sport halls.	Hot galvanised sheet metal, or plastic coated sheet metal.
C3 medium	Urban and industrial atmospheres, moderate sulphur dioxide pollution. Coastal areas with low salinity.	Production rooms with high humidity and some air pollution, e.g. food-processing plants, laundries, breweries, dairies.	Hot galvanisation after assembly.
C4 high	Industrial areas and coastal areas with moderate salinity.	Chemical plants, swimming pools, coastal ship- and boatyards.	Hot galvanisation after assembly.
C5-I very high (industrial)	Industrial areas with high humidity and harsh atmosphere.	Buildings or areas with almost permanent condensation and with high pollution.	Hot galvanisation and epoxy painting after assembly. Acid-proof steel. Surface treatment chosen case-by-case.
C5-M very high (marine)	Coastal and offshore areas with high salinity.	Buildings or areas with almost permanent condensation and with high pollution.	Hot galvanisation and epoxy painting after assembly. Acid-proof steel. Surface treatment chosen case-by-case.

Notes:

1. The loss values used for the corrosivity categories are identical to those given in ISO 9223.
2. In coastal areas in hot, humid zones, the mass or thickness losses can exceed the limits of category C5-M. Special precautions must therefore be taken when selecting protective paint systems for structures in such areas.

SURFACE TREATMENTS

Hot galvanised steel sheet

Sheet metal is hot galvanised on continuously moving production lines. The basic material is cold-rolled steel sheeting. After degreasing, the sheet is pickled and oxidised, after which surface oxides are removed by a reduction in temperature to 950°C, which also simultaneously softens the steel. The surface of the sheet is now purified metal and is transferred directly into a zinc bath. The sheet is then vertically driven out of the bath between air jets, to remove excess zinc from the surface of the sheet while the zinc goes back into the bath, leaving the desired coating. Computerised measurement systems are used to measure the thickness of the coating, while the operation of the air jets is also computerised. After cooling, straightening and white rust prevention treatment, the sheet is either delivered to the cutting press, rolled, or transferred to the plastic coating line.

MekaJohtotiet Oy produces KS20 and KS30 cable ladders, MEK lighting tracks, and KRA, KRB, KRC cable trays from hot galvanised sheet metal. These products include a coating thickness of approximately 20 µm of zinc. They are suitable for installation in dry environments, such as in offices, shops, hospitals, factories etc.

The hot galvanised steel sheet used by MekaJohtotiet Oy is galvanised according to the SFS-EN 10142 standard, which is equal to the ASTM A 653 standard, and the old SS 141151 and DIN 17162 standards.

Hot galvanising by immersion

Grease, oil, and soot are usually removed using an alkaline degreasing solution. After flushing with water rust and rolling scale are removed from the surfaces by pickling the steel in diluted hydrochloric acid or sulphuric acid. Prior to the sheet being immersed in molten zinc, it has to be treated with a fluidiser, to remove oxides from the surfaces of both the steel sheet and the bath in order to allow the steel and zinc to form a metallic bond between each other. After the fluidised bath treatment, the substrates are dried. A thin layer of fluidiser salt is left on the surfaces of the objects. After this, the object is immersed in the zinc, after which it is ready for final cleaning, inspection and loading. Mekajohtotiet Oy hot galvanises all cable ladders KS80, KSE80, KSF80 and their installation accessories using this method, according to the SFS-EN 1461 standard, which corresponds to the old SFS 2765 and DIN 50976 standards.

These products include a coating thickness of approximately 60 µm of zinc.

Duplex treatment

Hot galvanisation usually provides more than adequate protection against corrosion. In some cases however, additional protection may be needed if the environment is exceptionally corrosive. Duplex treatment gives the customer lasting protection against corrosion and in addition, the opportunity to choose a colour to go with the rest of the interior.

The zinc surface must be thoroughly cleaned before painting in order to ensure good adhesion, and an appropriate paint type must be used. After careful preparation, cable ladders and accessories are powder painted and finally hardened in an oven. MekaJohtotiet Oy's cable ladder system PEX is Duplex treated.



INSTALLATION INSTRUCTIONS

TECHNICAL REQUIREMENTS

Before using the cable trays, please read the following standards and regulations and the installation instructions in the product folder:

1. Standard SFS 3209 "Switchboard and telecommunications spaces, cable conduits" contains instructions for measuring the area needed for cable trays.
2. ST card ST 51.13 "Cable trays, ladders and track lighting".
3. ST card ST 841.05 "Layouts for cable trays"
4. ST cards ST 51.91 and ST 841.10 present the ways in which ducts are made.
5. ST card ST 13.51 presents the CAD graphic symbols of cable trays.

GENERAL INSTALLATION INSTRUCTIONS

Installation is performed in a way that deflection does not exceed 1/200 in visible cable trays and lighting tracks. In industrial and hidden cable trays and lighting tracks deflection must not exceed 1/100. An additional allowance of approx. 50% of the existing load must be included when calculating deflection.

Sufficient room for heat expansion must be left at the ends and between cable trays and lighting tracks. The heat expansion coefficient of steel is 0.000012 m/°C.

Cable trays and lighting tracks are fixed in a manner which does not allow them to slant or twist laterally.

The load bearing capacity of brackets and the strength of fixing and surface materials must be taken into consideration as cable trays and lighting tracks are installed.

In places where vertical trays are subject to physical damage, they should be protected up to a height of 1.5 m with a protective cover.

Ducts

When cable trays pass a fire-wall they must be cut. At borders of fire areas, the ducts must correspond to the fire endurance of the material being cut through. Different fire-proof cable ducts are presented in ST card 51.18.

The principles of sound insulation in connection with cable trays and lighting tracks passing through walls are presented in ST card 51.19.

Cables

Insulated cables are the most common cables used. External factors such as heat must be considered as cables are installed. Similarly, the effect of the strongest continuous current on the temperature of the cable must be taken into consideration. On a horizontal tray, cables are usually placed neatly straightened without fastening. On vertical and slanting trays, cables are fastened to the tray at appropriate distances with suitable fasteners.

Accessories

Accessories, such as branch boxes, which are installed on cable trays or lighting tracks are to be fastened firmly and in such a manner that they do not obstruct the actual cable space. Mountings, supports and other accessories are used when needed.

Electrical conductivity of cable ladders

All of MekaJohtotiet Oy cable ladders, cable trays and lighting tracks have been tested for electrical conductivity in Sweden at SP (Swedish National Testing and Research Institute). If you would like to obtain the test results, contact MekaJohtotiet Oy's technical support staff.



USAGE OF MEK LIGHTING TRACKS

MEK lighting tracks are used in offices and shops, in department stores, industrial areas and warehouses. Electric cables are easy to fix to the tracks because of the perforation on the underside of each track unit.

MekaJohtotiet Oy's painted lighting tracks and lighting fixtures form an important part of any interior, while the extensive selection of installation parts enables the building of a large variety of lighting solutions.

The standard delivery length is 6 meters, while other lengths can be delivered on short notice. MEK lighting tracks are made of hot galvanised (MEK 70, MEK 70 K, and MEK 110), or plastic coated steel sheeting (MEK 70M and MEK 110M).

The standard colour is white (RAL 9010, NCS 0502-Y). Other colours are also delivered upon request. MEK lighting tracks can be used in SFS-EN ISO 12944-2 corrosion categories C1 and C2.

TO BE TAKEN INTO CONSIDERATION

1. Cable trays and lightning tracks are intended only for supporting cables and luminaries.
2. As cable trays and other conduit products are installed, the load carrying capacity of brackets isto be observed, and care should be taken to see that there is sufficient strength in the fixtures and surface materials.
3. Cable trays must not be used as ladders or walk-ways.
4. The manufacturer is not responsible for direct or indirect damages caused by inappropriate use of any of our products.



LIGHTING TRACK

Lighting track MEK

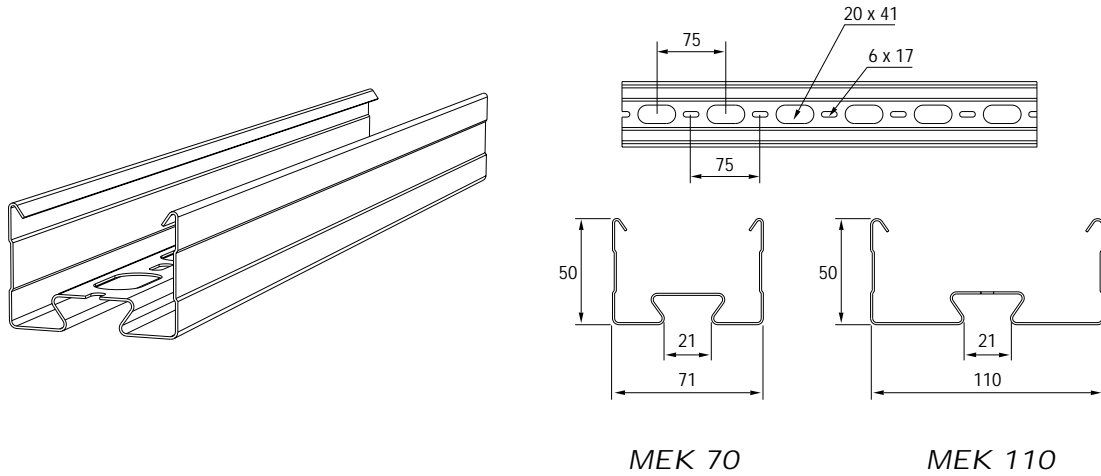

Product	SSTL number	Package m	Weight kg/100 m	Length m	Material thickness mm
---------	-------------	-----------	-----------------	----------	-----------------------

Hot galvanised sheet metal

MEK 70 K	14 493 11	180	130	6	0.75
MEK 70	14 493 12	180	170	6	1.00
MEK 110	14 493 13	108	200	6	1.00

Hot galvanised plastic coated sheet metal, colour white RAL 9010

MEK 70 M	14 493 15	180	130	6	0.75
MEK 110 M	14 493 17	108	200	6	1.00

Load curves

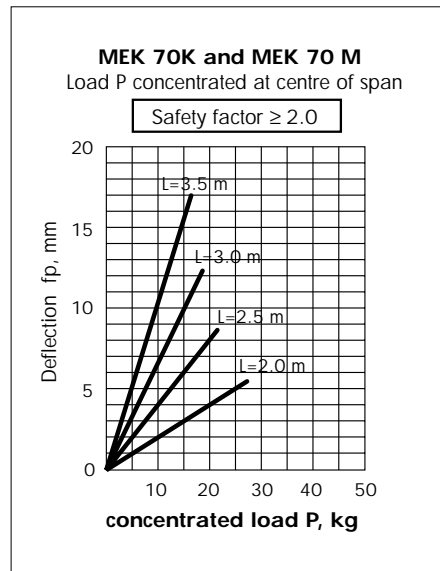
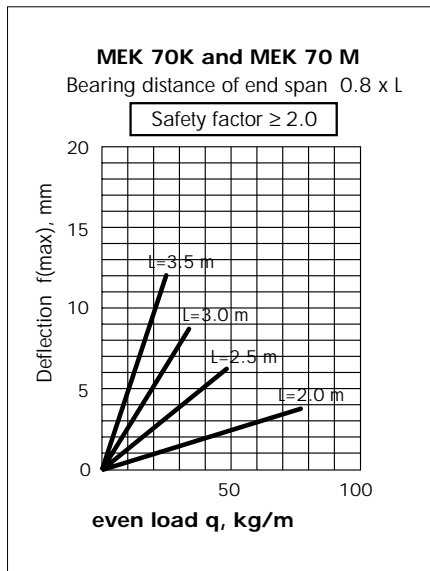
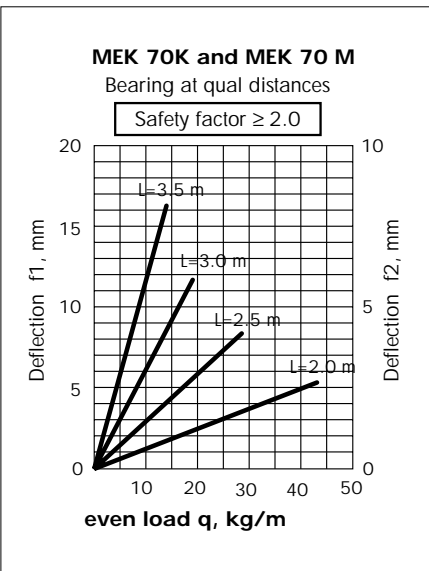
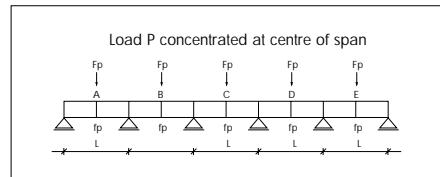
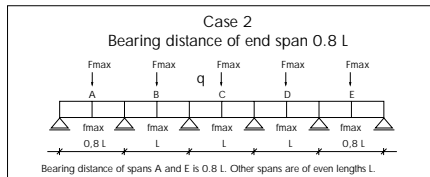
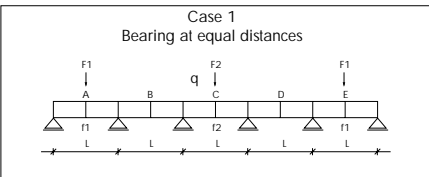

LIGHTING TRACK

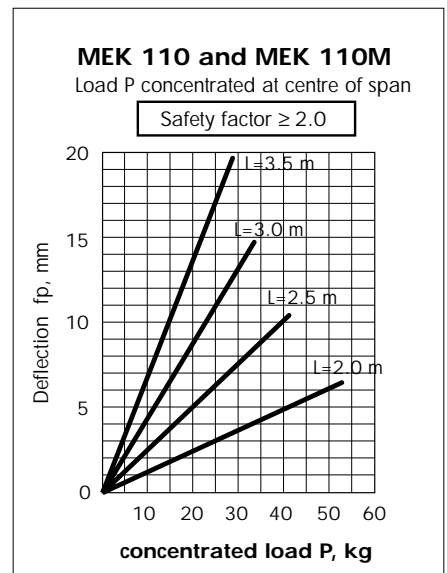
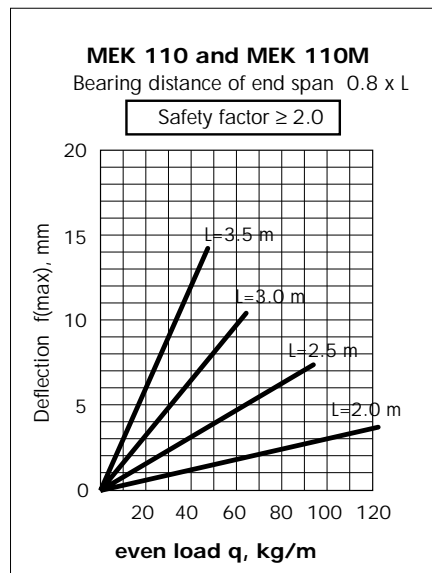
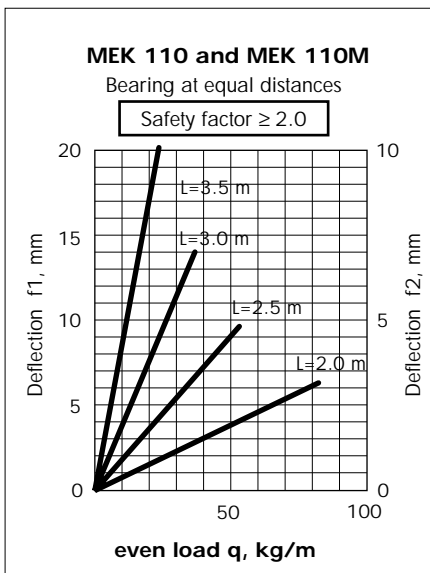
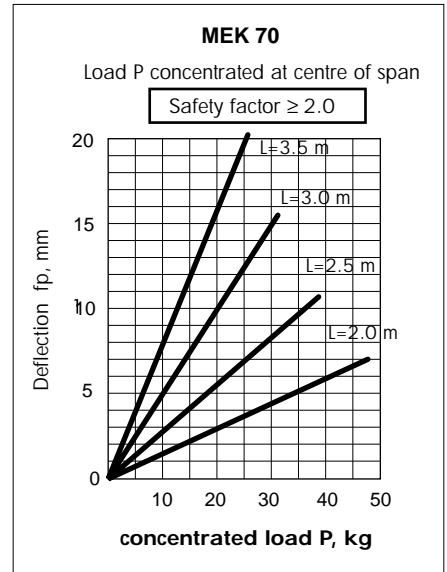
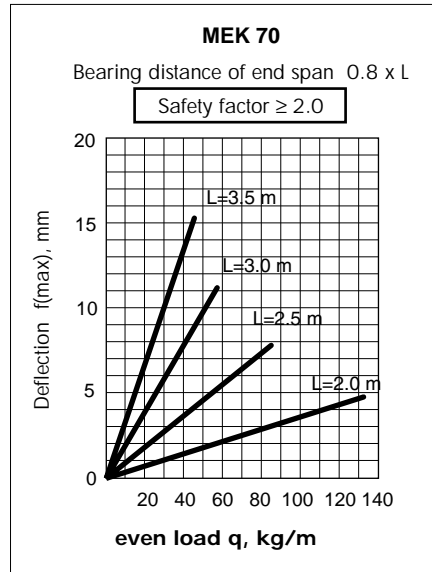
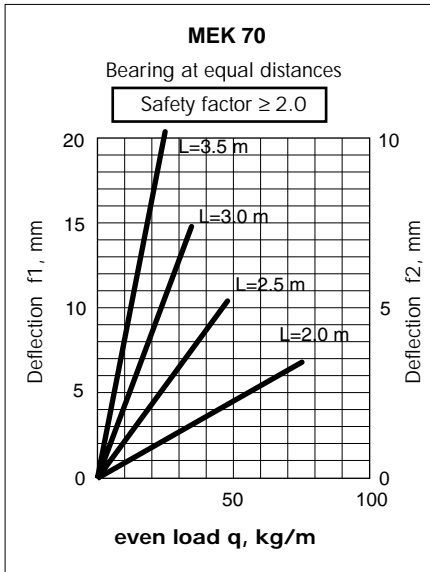

Explanation of the lighting track load curves

A five-span load-bearing beam is illustrated above (Case 1), in which the deflection f_1 is measured in spans A and E. In long installations, the deflection is demonstrated by f_2 . If the end of the ladder is securely fastened to the wall then, where the ladder begins, deflection f_2 is used. If there is no end attachment, and if the load is at equal distances, the deflection of spans A and E can be measured at f_1 , and the deflection of other spans, at f_2 . If the end of the ladder is not attached to the wall, and the deflection is to be decreased (Case 2), the bearing distance for spans A and E must be reduced by 20%, ie. $0.8 \times L$ (L = bearing

load at equal distances), in which case the load corresponds to the load in Case 2. The maximum deflection in each support span in Case 2 is demonstrated in the corresponding load curve. Deflection is also influenced by the type of the extensions which are used and by the method used to support the extensions. The value at the end of each load curve represents the maximum permitted load (safety factor ≥ 2), which must not be exceeded. In the case of a concentrated load see the deflection for various spans from the appropriate curves.

ANGLE-, T- AND X-PIECES

Angle piece MEK KR

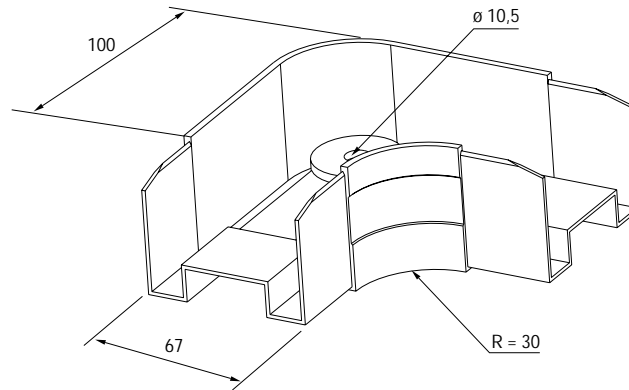

Maximum load allowed 30 kg

Product	SSTL number	Package pc	Weight kg /100 pcs
Plastic, grey			
MEK KR-70	14 493 29	4	10
Plastic, white			
MEK KR-70 M	14 493 30	4	10

Installation example

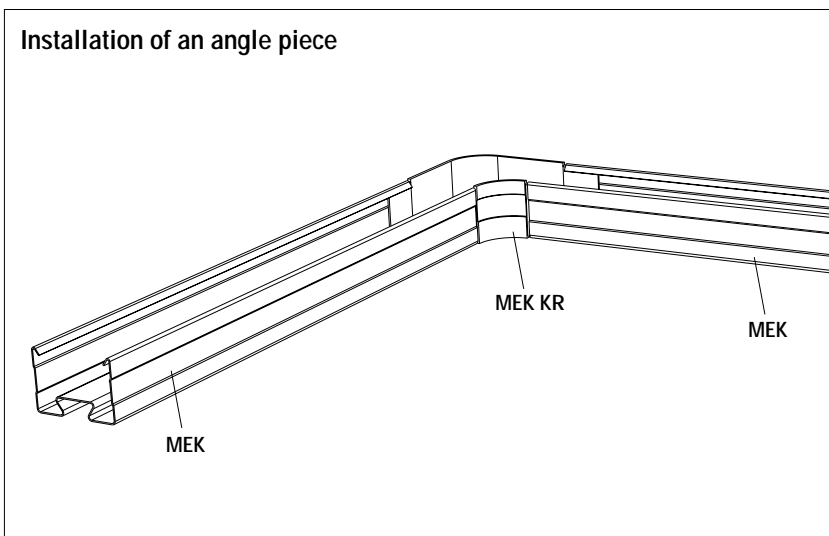

Angle piece MEK KR is pushed into a lighting track as shown. The fixing is made secure with rivets or screws.

ANGLE-, T- AND X-PIECES

Angle piece MEK KU

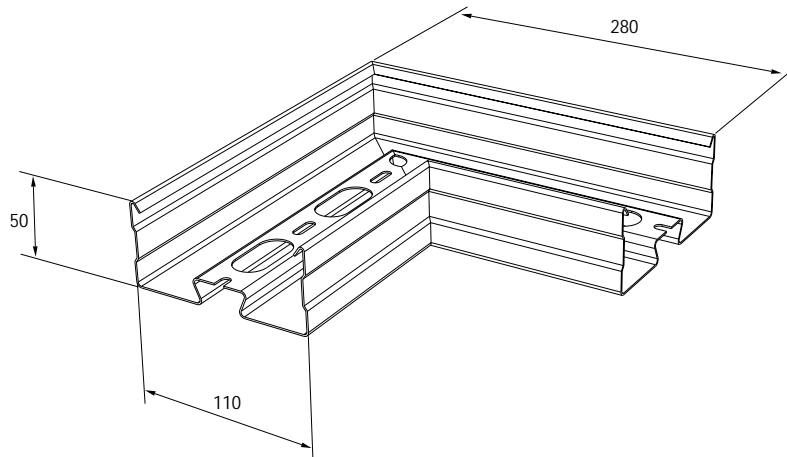

Product	SSTL number	Package pc	Weight kg /100 pcs
---------	-------------	------------	--------------------

Hot galvanised sheet metal

MEK KU-110	14 493 42	1	93
------------	-----------	---	----

Hot galvanised and painted sheet metal

MEK KU-110 M	14 493 47	1	93
--------------	-----------	---	----

Installation example

Installation of an angle piece

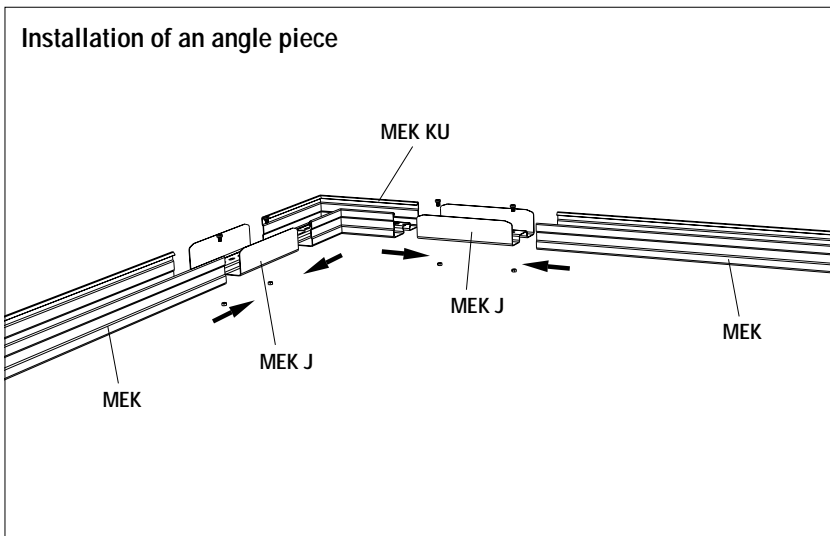

Angle piece MEK KU is installed onto a lighting track using two joints MEK J. See use of the MEK J on page 25.

ANGLE-, T- AND X-PIECES

T-piece MEK TR

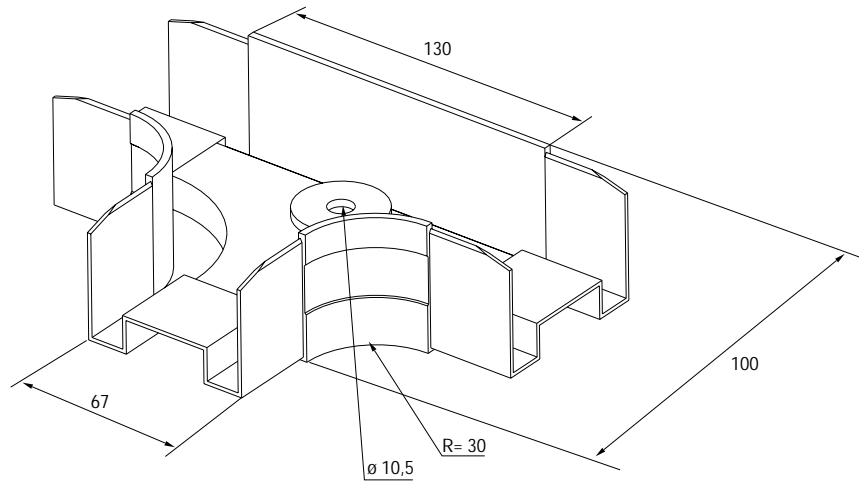

Maximum load allowed 30 kg

Product	SSTL number	Package pc	Weight kg /100 pcs
Plastic, grey			
MEK TR-70	14 493 32	4	10
Plastic, white			
MEK TR-70 M	14 493 33	4	10

Installation example

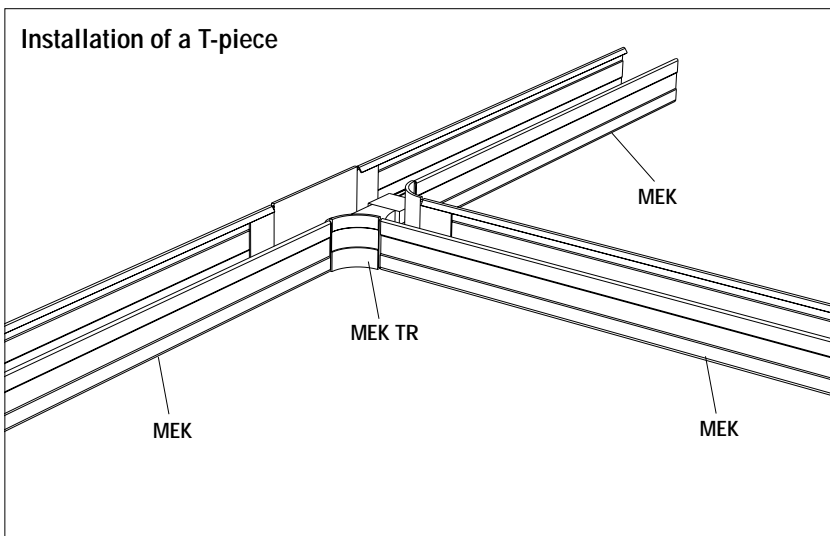

T-piece MEK TR is pushed inside a lighting track as shown. The fixing is secured with rivets or screws.

X-piece MEK XR

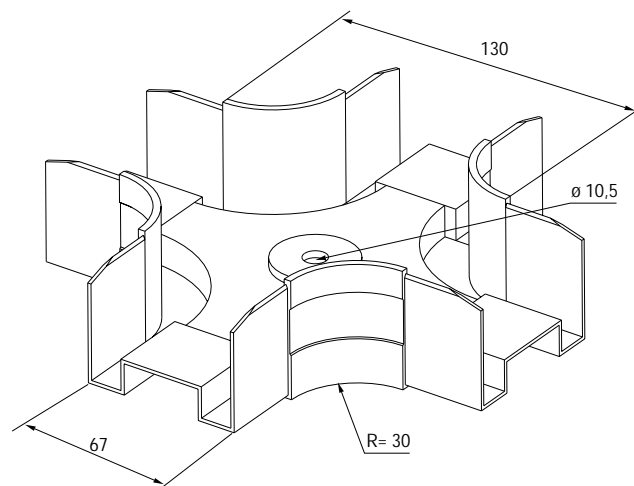

Maximum load allowed 30 kg

Product	SSTL number	Package pc	Weight kg /100 pcs
Plastic, grey			
MEK XR-70	14 493 35	4	10
Plastic, white			
MEK XR-70 M	14 493 36	4	10

Installation example

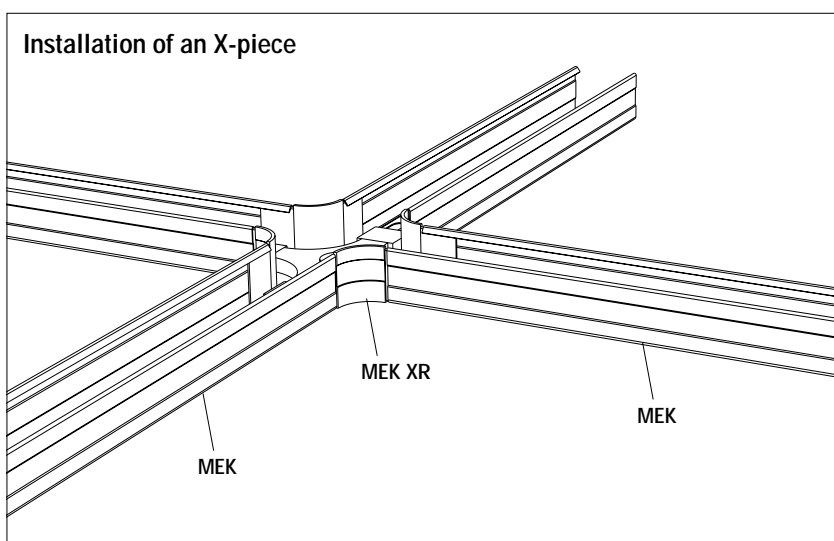

X-piece MEK XR is pushed inside a lighting track as shown. The fixing is secured with rivets or screws.

BRACKETS

Edge bracket MEK RK

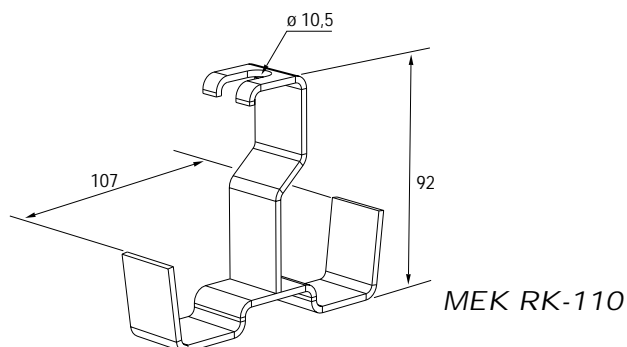
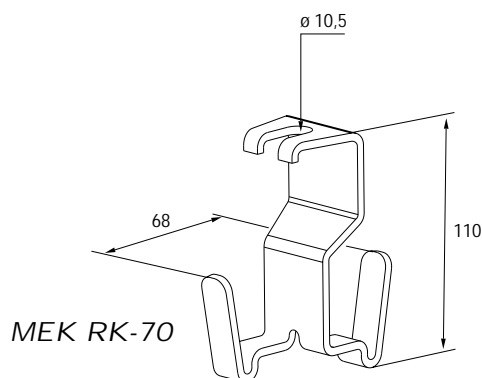

Product	SSTL number	Package pc	Weight kg /100 pcs
---------	-------------	------------	--------------------

Hot galvanised sheet metal

MEK RK-70	14 493 56	20	12
MEK RK-110	14 493 57	10	13

Hot galvanised and painted sheet metal

MEK RK-70M	14 493 89	20	12
MEK RK-110M	14 493 90	10	13

Installation examples

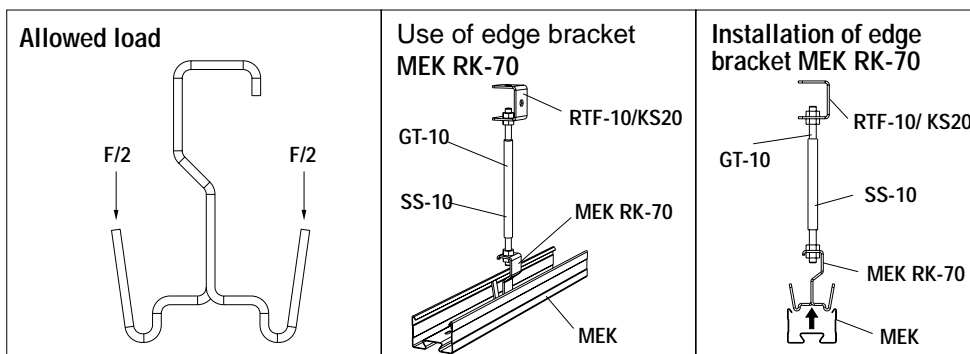

Allowed load F of edge bracket MEK RK-70 with symmetrical load is 500 N = 50 kg.

Edge bracket MEK RK-70 is used to support lighting tracks MEK 70, MEK 70 K and MEK 70 M.

Edge bracket MEK RK-70 is fixed onto threaded rod GT-10 with two M 10 nuts. The threaded rod is fixed onto the ceiling either with ceiling support RTF-10, or with a wedge anchor. After the ceiling support is finished, a lighting track is pushed in place onto the edge bracket.

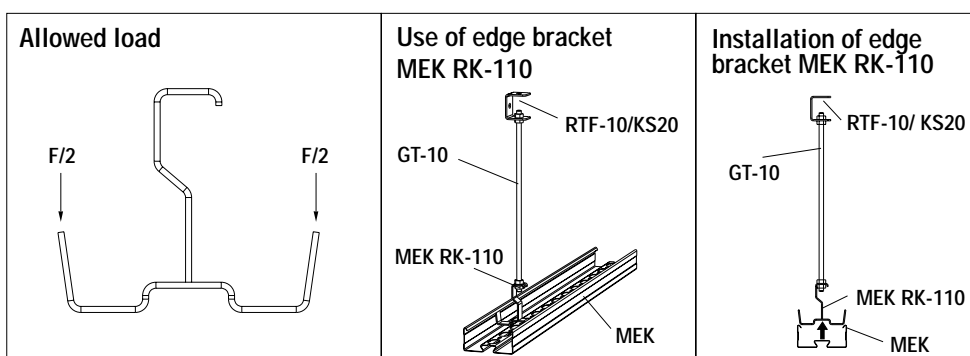

Allowed load F of edge bracket MEK RK-110 with symmetrical load is 600 N = 60 kg.

Edge bracket MEK RK-110 is used to support lighting tracks MEK 110 and MEK 110 M.

Edge bracket MEK RK-110 is fixed onto threaded rod GT-10 with two M 10 nuts. The threaded rod is fixed onto the ceiling either with ceiling support RTF-10, or with a wedge anchor. After the ceiling support is finished, a lighting track is pushed in place onto the edge bracket.

BRACKETS

Wall bracket MEK SK

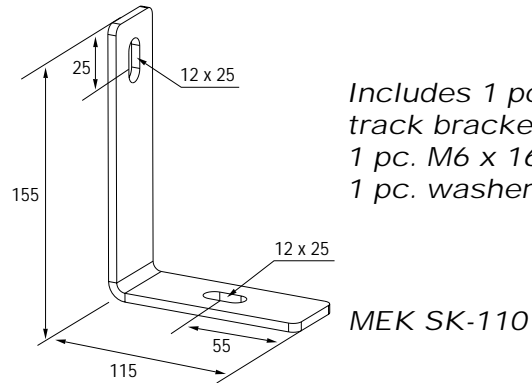
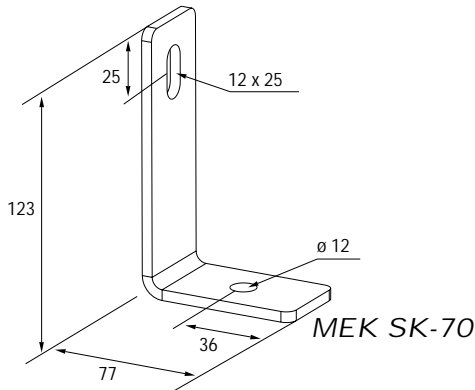

Includes 1 pc. lighting track bracket MEK VM, 1 pc. M6 x 16 bolt and 1 pc. washer / product.

Product	SSTL number	Package pc	Weight kg /100 pcs
---------	-------------	------------	--------------------

Zinc electroplated

MEK SK-70	14 493 61	10	28
MEK SK-110	14 493 62	10	38

Zinc electroplated and painted

MEK SK-70M	14 493 79	10	28
MEK SK-110M	14 493 80	10	38

Installation examples

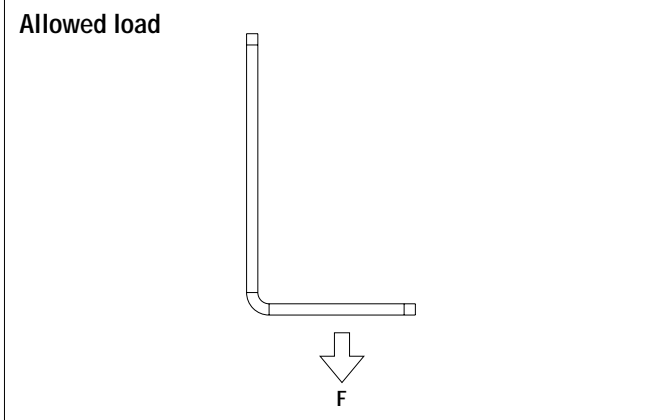

Allowed load F of wall bracket MEK SK is 1.4 kN = 140 kg.

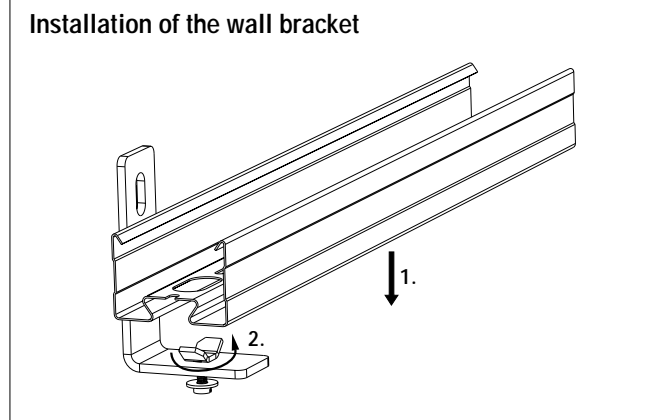

Wall bracket MEK SK is used when a lighting track is fixed to a wall. After the bracket is fixed to the wall, a lighting track bracket is fixed onto the wall bracket. Lift the lighting track on top of the wall bracket. Turn the track bracket perpendicular to the track inside the slot and screw the bolt tight.

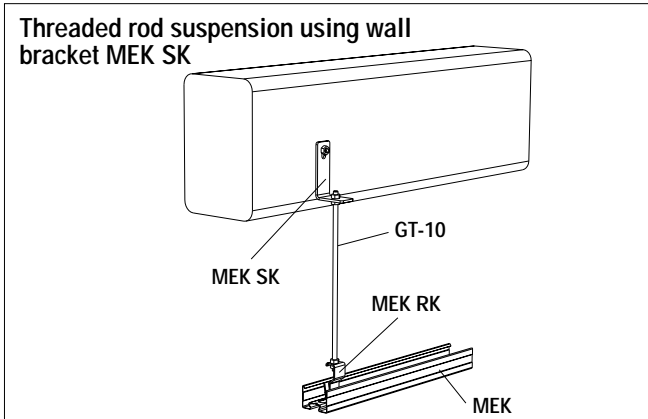

By using wall bracket MEK SK, threaded rod GT and edge bracket MEK RK, the lighting track can be fixed to the side of a steel or concrete beam.

BRACKETS

End bracket MEK PK

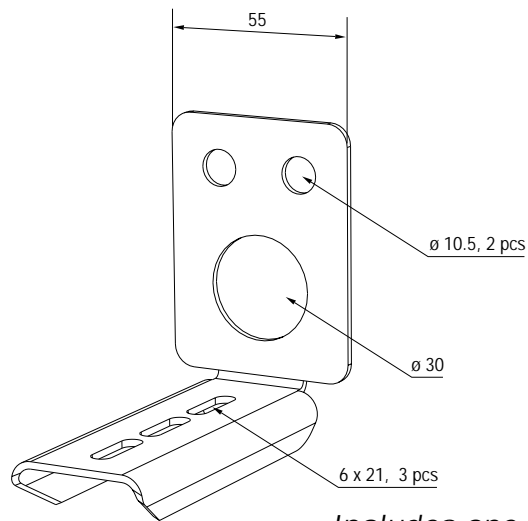

Includes one M5 x 8 Phillips bolt,
and one M5 collar nut
(bolt set MEK J) / product

Product	SSTL number	Package pc	Weight kg /100 pcs
Hot galvanised sheet metal			
MEK PK	14 493 73	10	13
Hot galvanised and painted sheet metal			
MEK PK M	14 493 74	10	13

Installation examples

Installation of an end bracket

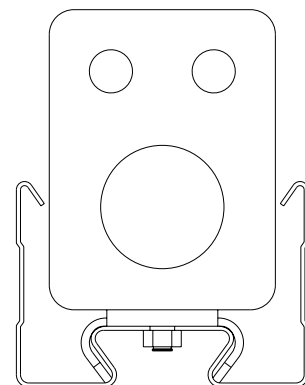
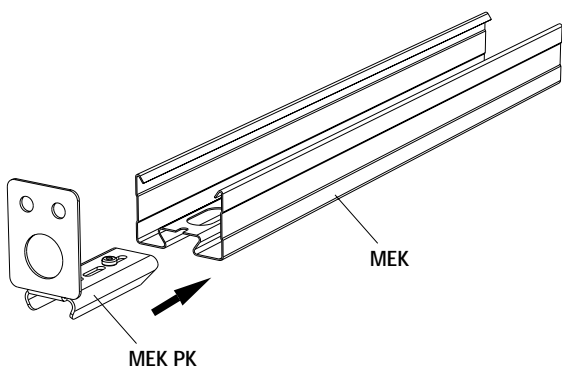

End bracket MEK PK is used when the end of a lighting track is fixed to a wall. End bracket MEK PK is fixed to the lighting track using the bolt set provided. MEK PK is suitable for all lighting track types.

BRACKETS

T-piece MEK T

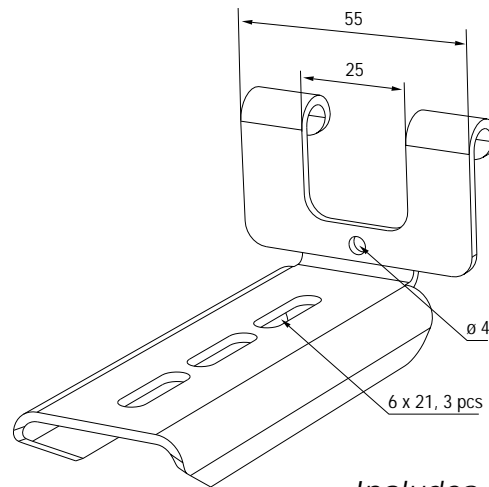

Includes one M5 x 8 cross head bolt,
and one M5 collar nut
(bolt set MEK J) / product

Product	SSTL number	Package pc	Weight kg /100 pcs
Hot galvanised sheet metal			
MEK T	14 493 83	10	12
Hot galvanised and painted sheet metal			
MEK T M	14 493 84	10	12

Installation examples

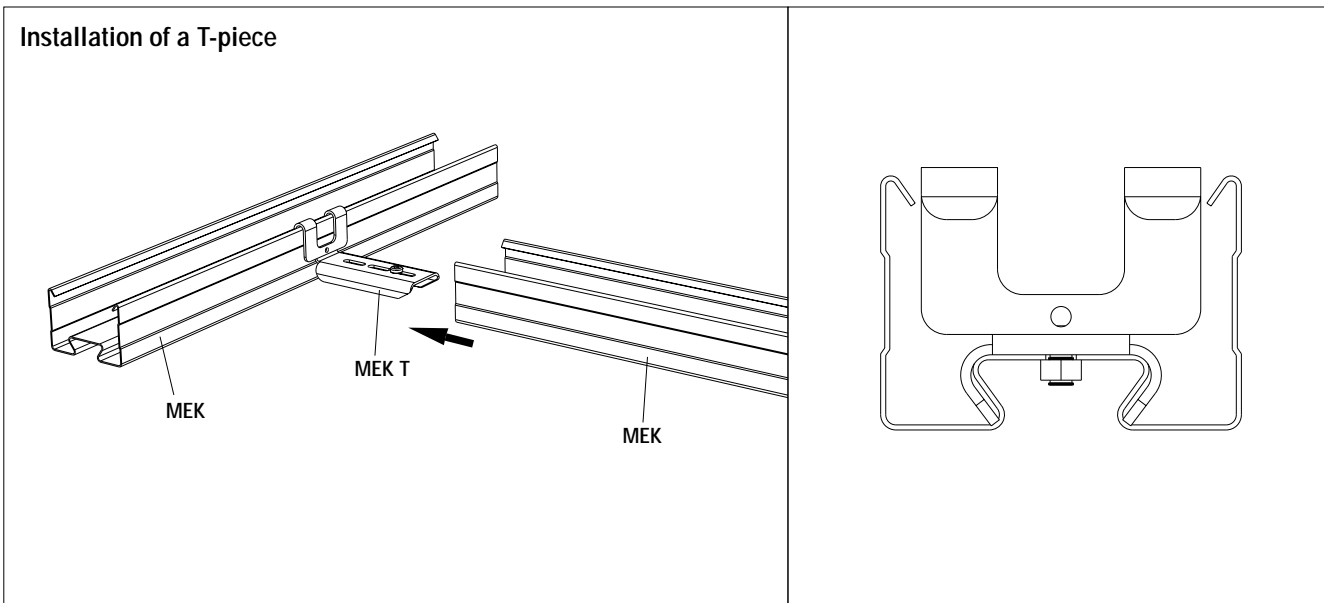

T-piece MEK T is used when the end of a lighting track is fixed to the side of another track to form a T-connection. T-piece MEK T is fixed to the dovetail slot of a lighting track with the bolt set provided, and onto the side of the intersecting track using a self-tapping screw or a rivet. An opening for cables can be made in the side of the intersecting lighting track. MEK T is suitable for all lighting track types.

BRACKETS

Adjustable edge bracket MEK RPF

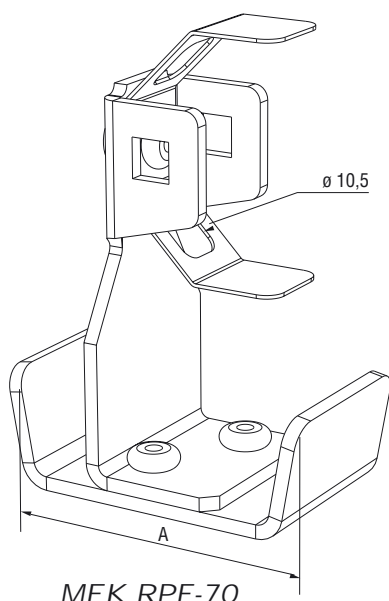

MEK RPF-70

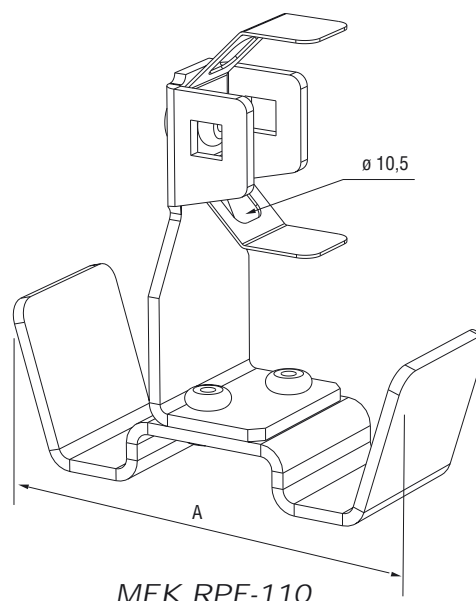

MEK RPF-110

Product	SSTL number	Package pc	Weight kg /100 pcs	A mm
Hot galvanised sheet metal				
MEK RPF-70	14 493 37	10	22	68
MEK RPF-110	14 493 43	10	29	108
Hot galvanised and painted sheet metal				
MEK RPF-70 M	14 493 38	10	22	68
MEK RPF-110 M	14 493 44	10	29	108

Installation examples

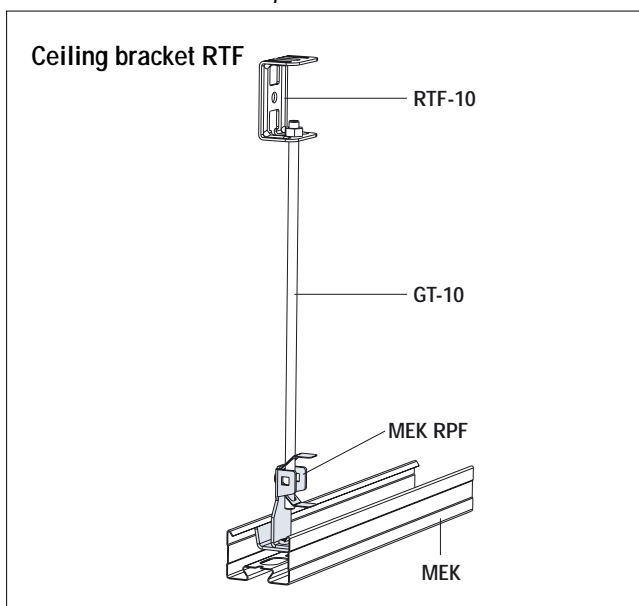

Adjustable edge bracket MEK RPF is fixed using threaded rod GT-10 and ceiling bracket RTF-10.

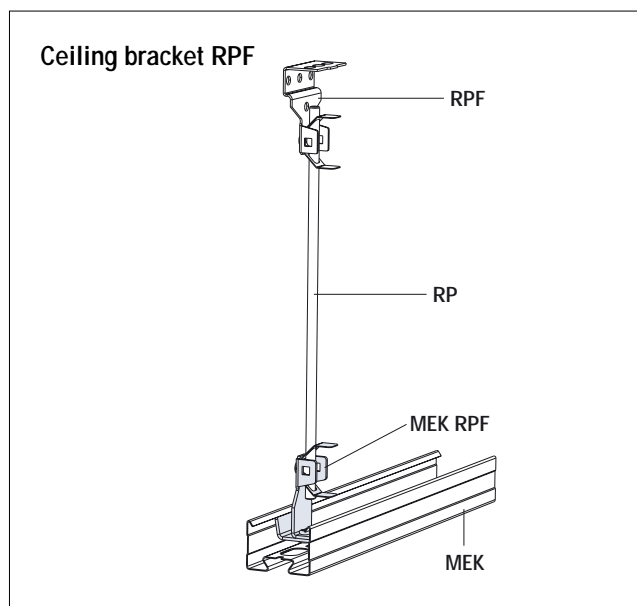

Lighting track MEK can be installed also by using adjustable bracket MEK RPF, tube RP and adjustable ceiling bracket RPF.

BRACKETS

Edge bracket MEK PF

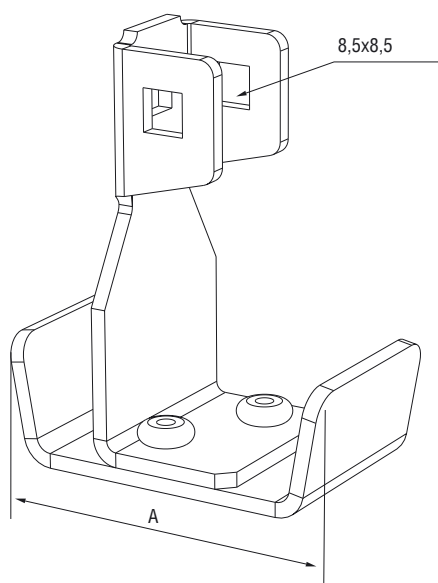

MEK PF-70

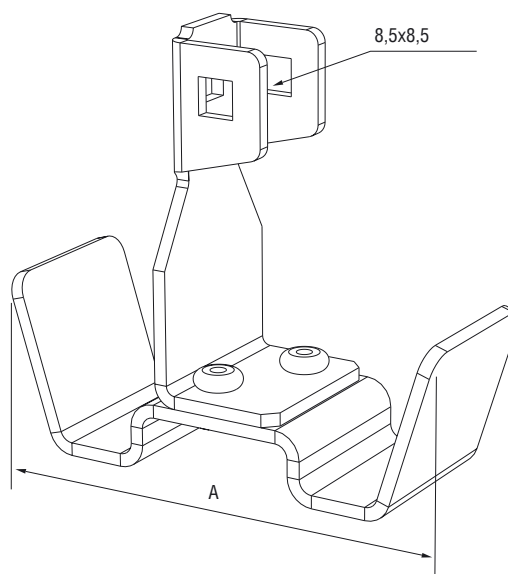

MEK PF-110

Product	SSTL number	Package pc	Weight kg /100 pcs	A mm
Hot galvanised sheet metal				
MEK PF-70	14 493 19	10	22	68
MEK PF-110	14 493 26	10	29	108
Hot galvanised and painted sheet metal				
MEK PF-70 M	14 493 25	10	22	68
MEK PF-110 M	14 493 27	10	29	108

Installation example

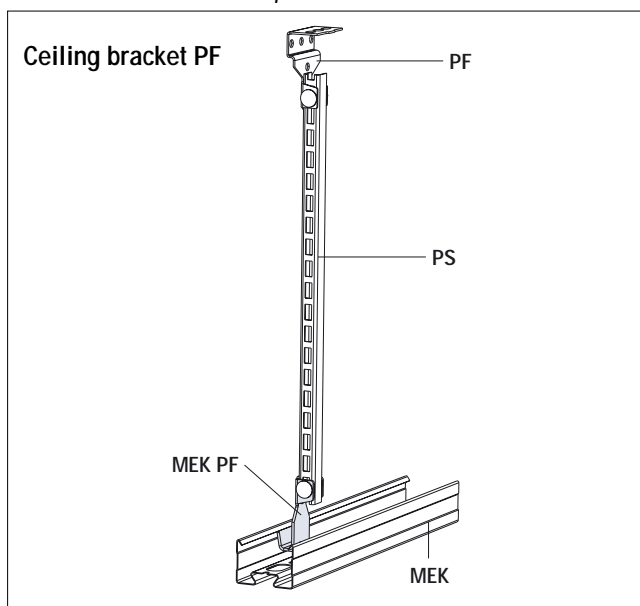

Edge bracket MEK PF is used to install lighting track MEK using supportive rail PS. PS rail can be fixed with brackets MEK PF and PF using bolt sets RS PF.

BRACKETS

Wire bracket MEK VR

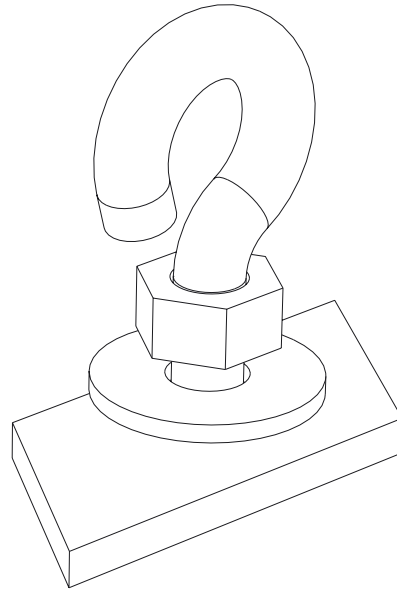

Product	SSTL number	Package pc	Weight kg /100 pcs
---------	-------------	------------	--------------------

Hot galvanised sheet metal

MEK VR	14 493 63	10	2
--------	-----------	----	---

Installation example

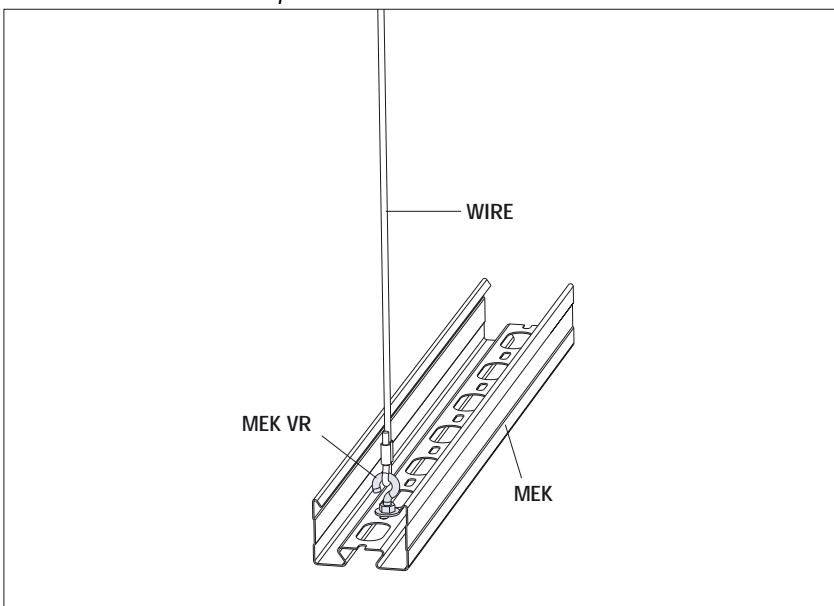

Wire bracket MEK VR is used to install lighting tracks MEK with wire. MEK VR is suitable for all MEK lighting tracks.

EXTENSION PIECES

Joint piece MEK J

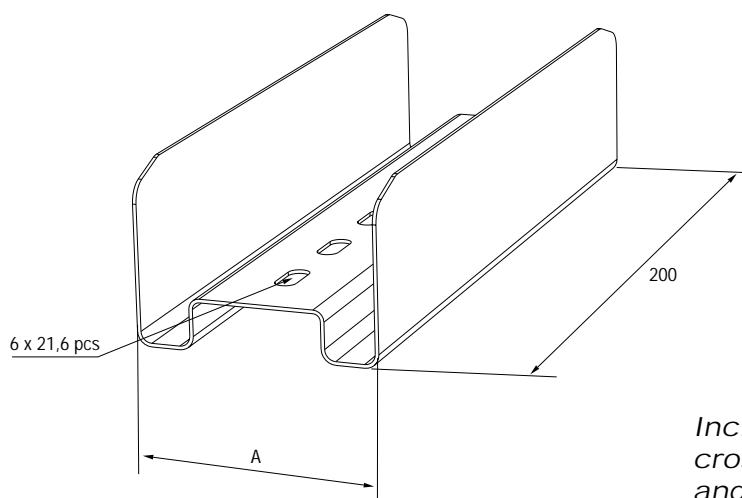

Includes two M5 x 8 cross head bolts, and two M5 collar nuts (bolt set MEK J) / product

Product	SSTL number	Package pc	Weight kg /100 pcs	A mm
Hot galvanised sheet metal				
MEK J-70	14 493 51	30	25	68
MEK J-110	14 493 52	10	30	108

Installation example

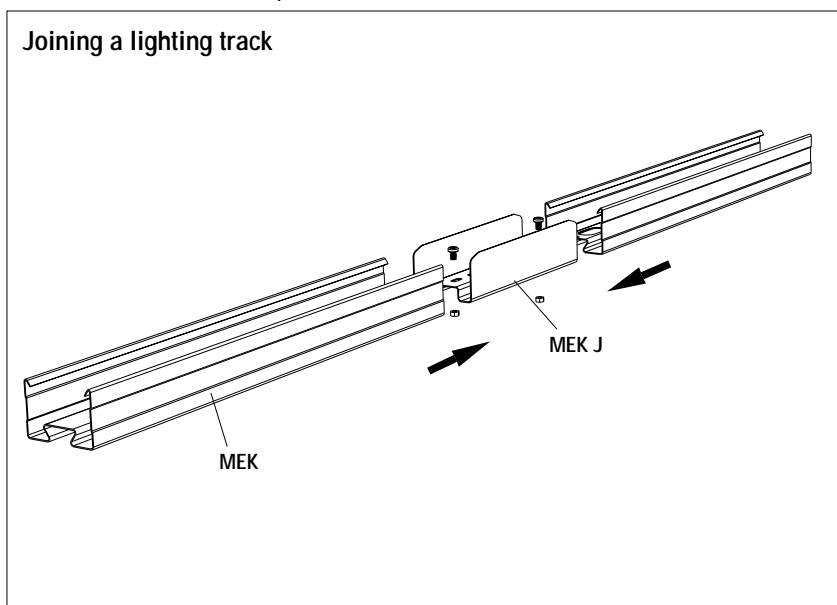

Joint piece MEK J is pushed inside a lighting track and fixed with the bolt sets provided.

EXTENSION PIECES

Elbow joint MEK NL

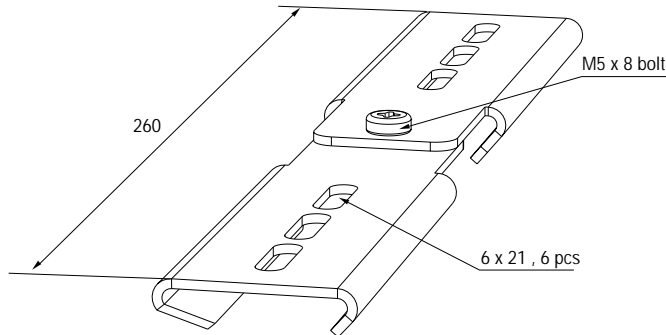

Includes three M5 x 8 cross head bolts and two M5 collar nuts (bolt set MEK J) / product.

Product	SSTL number	Package pc	Weight kg /100 pcs
Hot galvanised sheet metal			
MEK NL	14 493 22	10	21
Hot galvanised and painted sheet metal			
MEK NL M	14 493 24	10	21

Installation examples

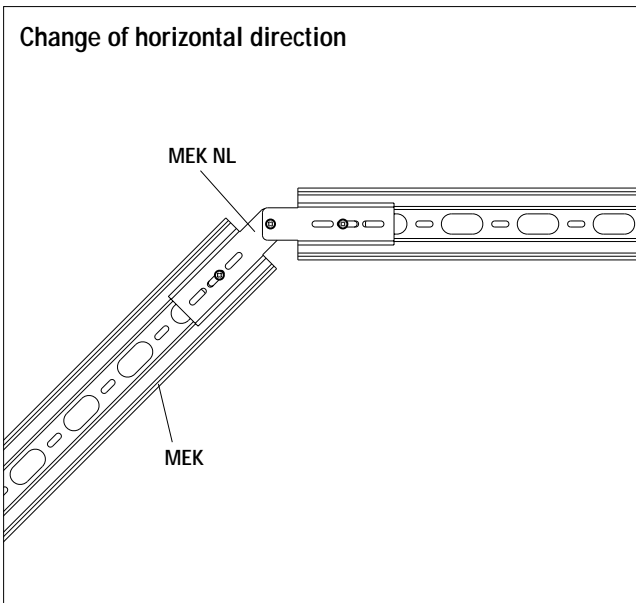

Elbow joint MEK NL can be used to make a change in the horizontal direction of a lighting track. The elbow joint is fixed onto the dovetail slot in the lighting track and secured using the bolt set provided. The extension can be made neaten by sawing the lighting track ends at angles which come together.

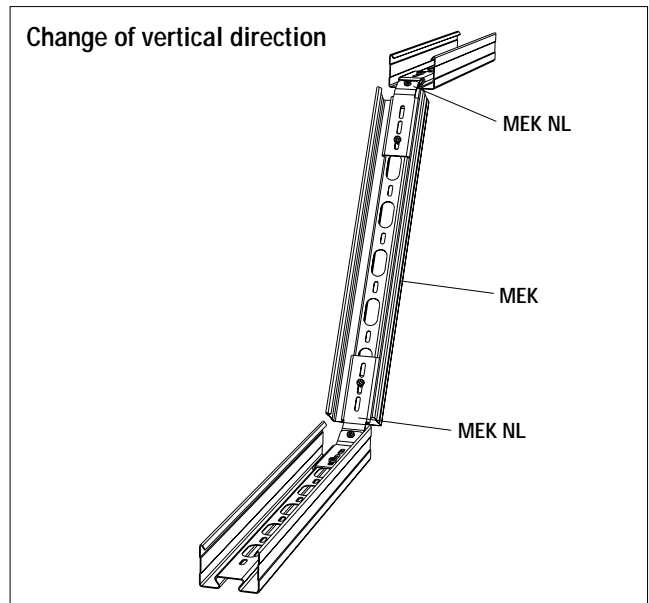

Elbow joint MEK NL can be used to make a change in the vertical direction of a lighting track. The elbow joint is fixed onto the dovetail slot in the lighting track and secured using the bolt set provided. The extension can be made neaten by sawing the lighting track ends at angles which come together.

INSTALLATION ACCESSORIES

Lighting nut MEK VM and MEK VM-L

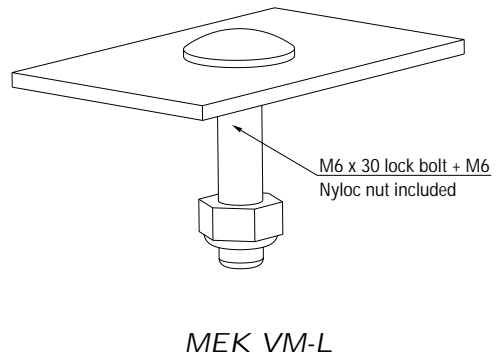
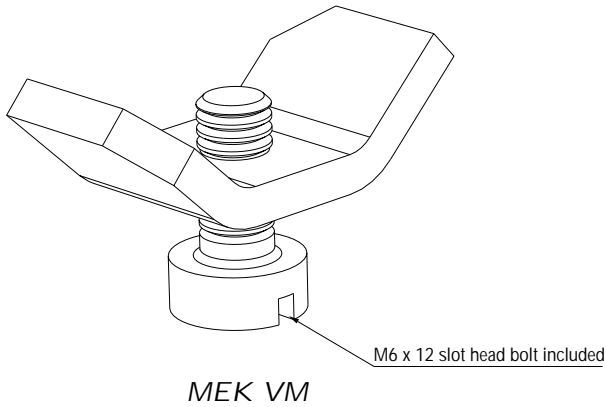

Product	SSTL number	Package pc	Weight kg /100 pcs
---------	-------------	------------	--------------------

Hot galvanised sheet metal			
MEK VM	14 493 55	100	2
MEK VM-L	14 493 54	100	2

Installation examples

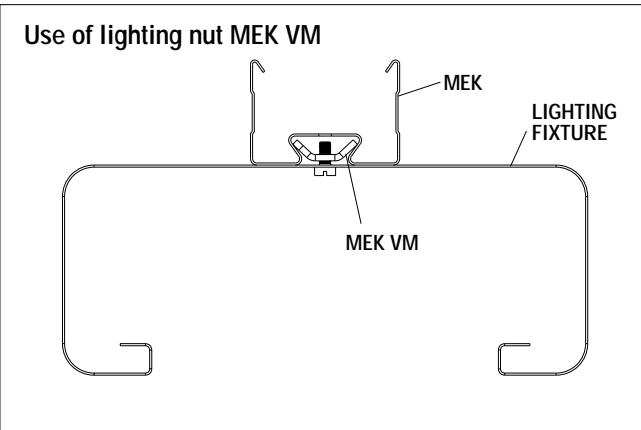

Lighting nut MEK VM is used to fix lighting fixtures onto a lighting track.

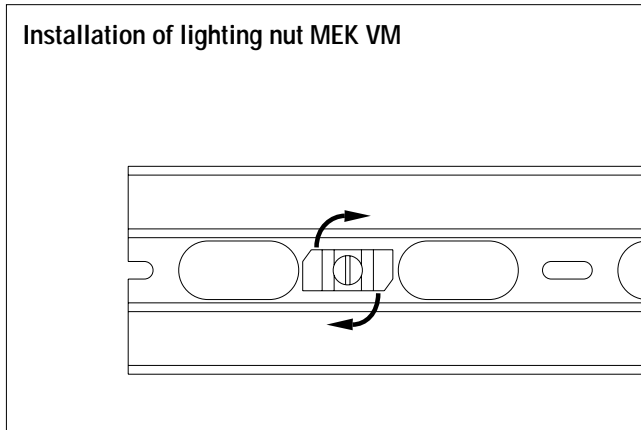

Lighting nut MEK VM is installed in the dovetail slot of a lighting track by turning it clockwise 90°. As the lighting fixture is tightened in place with the bolt, make sure that lighting nut MEK VM is at a right angle to the lighting track.

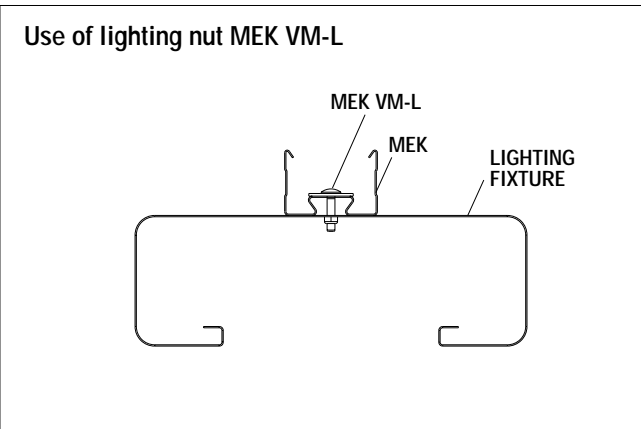

Lighting nut MEK VM-L is used to fix lighting fixtures onto lighting tracks in places where the fixtures are subject to resonance.

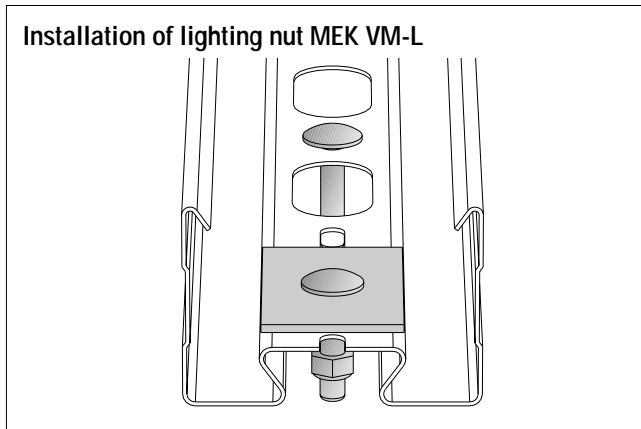

Lighting nut MEK VM-L is made up of a lock bolt, lock nut, and washer. The lock bolt is put through the perforation in the lighting track, and the lighting fixture is fixed with the lock nut. Use the washer if necessary.

Coupling plate RDP

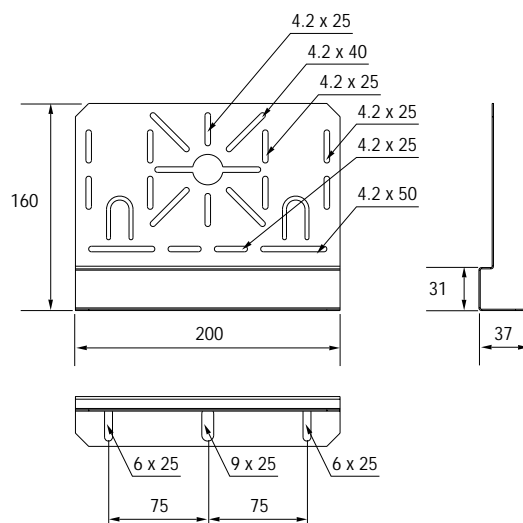
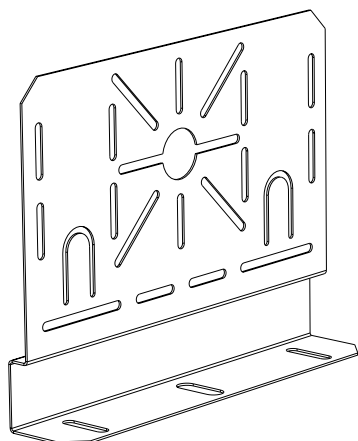

Includes two M5 x 8 cross head bolts, and two M5 collar nuts (bolt set MEK J) / product

Product	SSTL number	Package pc	Weight kg /100 pcs
---------	-------------	------------	--------------------

Hot galvanised sheet metal

RDP	14 316 49	10	27
-----	-----------	----	----

Hot galvanised and painted sheet metal

RDP M	14 316 50	10	27
-------	-----------	----	----

Installation examples

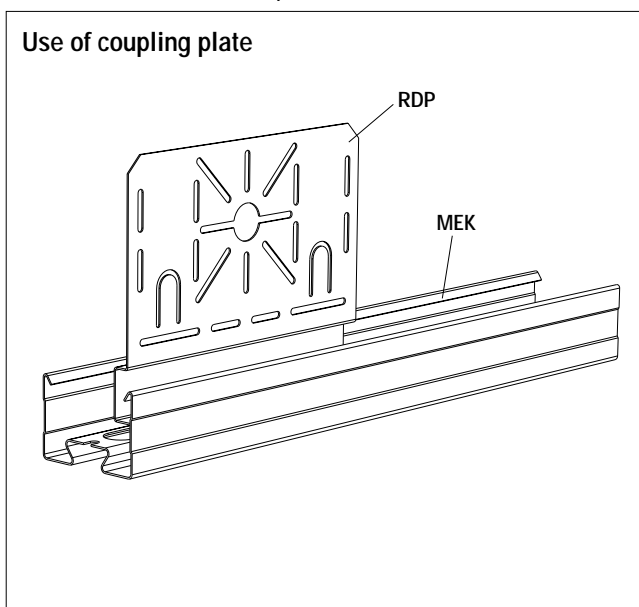

Mounting boxes can be fixed onto coupling plate RPD.

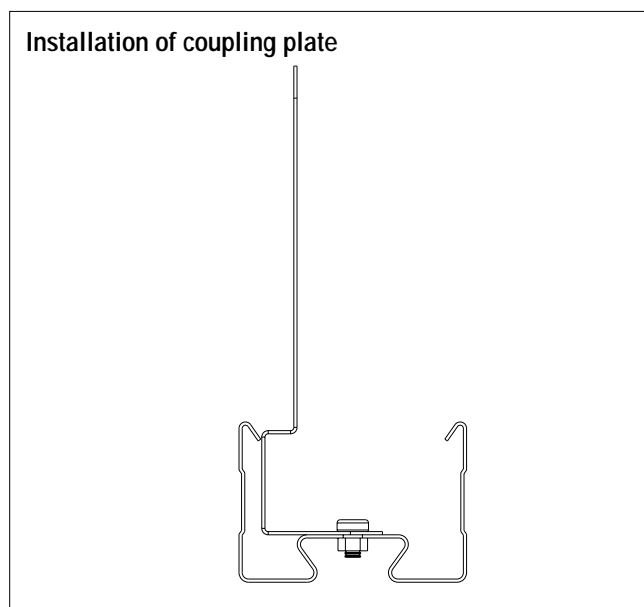

Coupling plate RPD is fixed onto the centre perforation of a lighting track with the bolt sets provided.

INSTALLATION ACCESSORIES

Coupling plate MEK KL MU

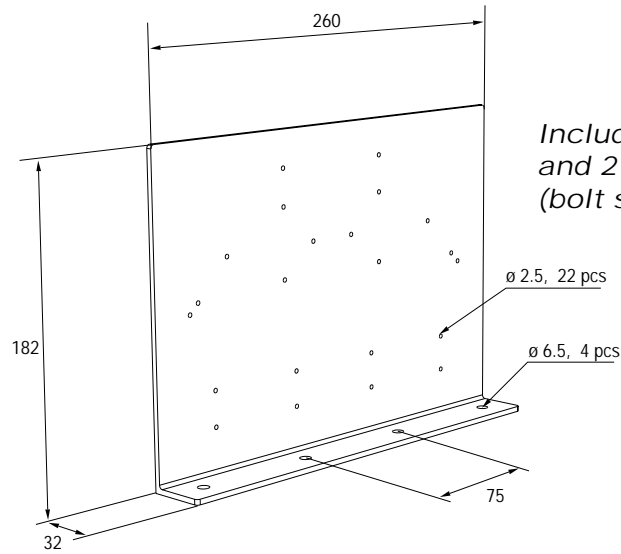

Includes 2 pcs. cross head bolts and 2 pcs. collar nuts (bolt set MEK J) / product

ø 2.5, 22 pcs

ø 6.5, 4 pcs

Product	SSTL number	Package pc	Weight kg /100 pcs
---------	-------------	------------	--------------------

Plastic, white

MEK KL MU	14 493 93	10	17
-----------	-----------	----	----

Installation examples

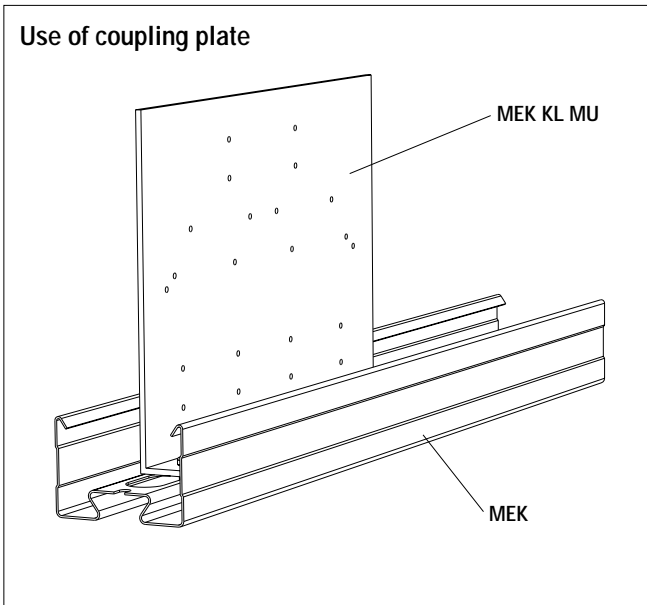

Coupling plate MEK KL MU is used when mounting boxes must be isolated from a conductive fixing place.

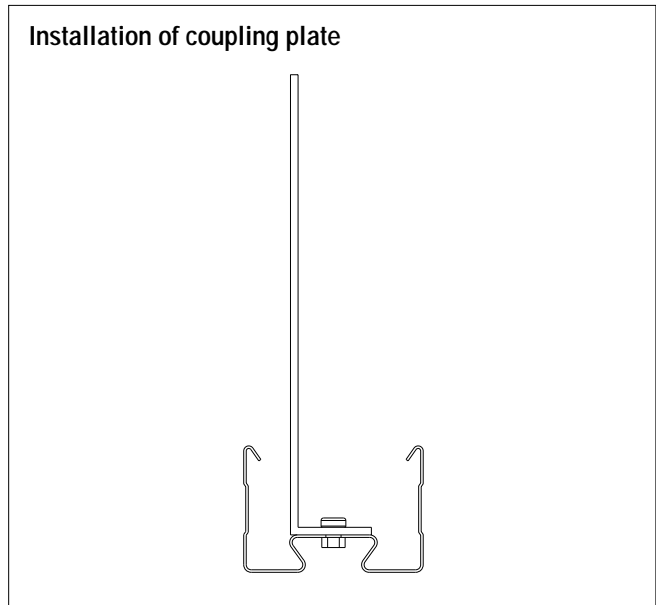

Coupling plate MEK KL MU is fixed onto a lighting track with the bolt sets provided.

Ceiling bracket RTF-10

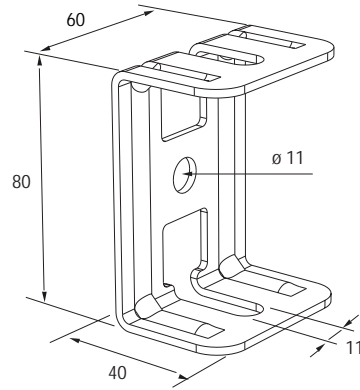

Product	SSTL number	Package pc	Weight kg /100 pcs
---------	-------------	------------	--------------------

Hot galvanised sheet metal

RTF-10/KS20	14 494 84	20	12
-------------	-----------	----	----

Hot galvanised and painted sheet metal

RTF-10 M	14 316 19	20	12
----------	-----------	----	----

Installation examples

Use of ceiling bracket

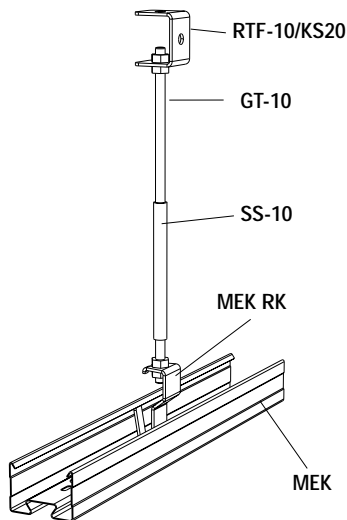

Ceiling bracket RTF-10/KS20 is used in fixing a threaded rod to a ceiling.

Threaded rod suspension from side of a beam

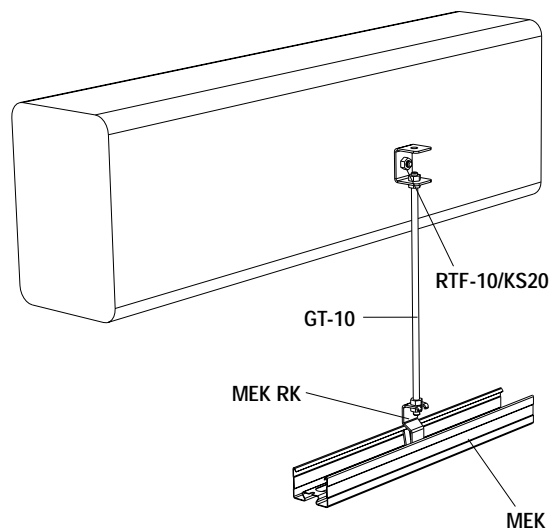

By using ceiling bracket RTF-10, threaded rod GT and edge bracket MEK RK the lighting track can be fixed to the side of a steel or concrete beam.

INSTALLATION ACCESSORIES

Ceiling bracket RTF-Z

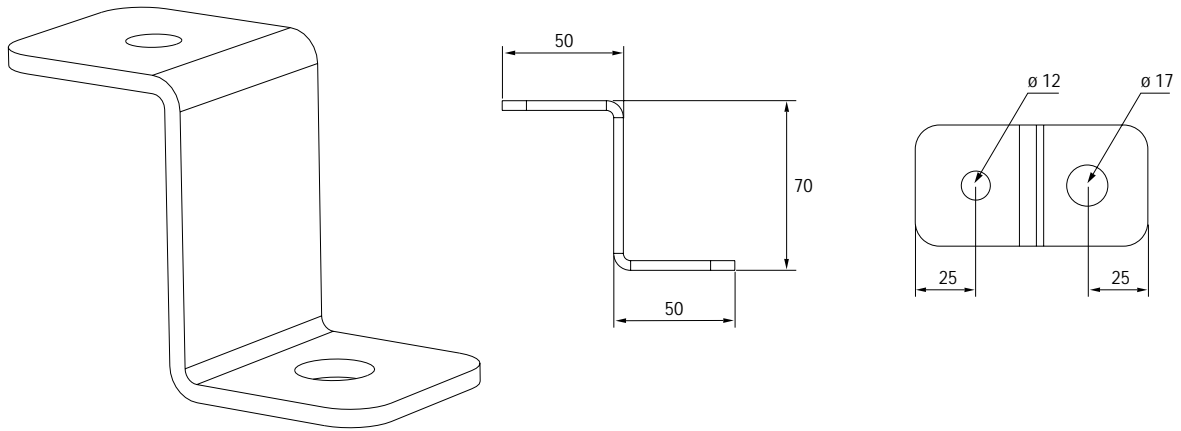

Product	SSTL number	Package pc	Weight kg /100 pcs
---------	-------------	------------	--------------------

Hot dip galvanised after manufacture

RTF-Z	14 496 56	10	23
-------	-----------	----	----

Hot dip galvanised and painted after manufacture

RTF-Z M	14 316 23	10	23
---------	-----------	----	----

Installation example

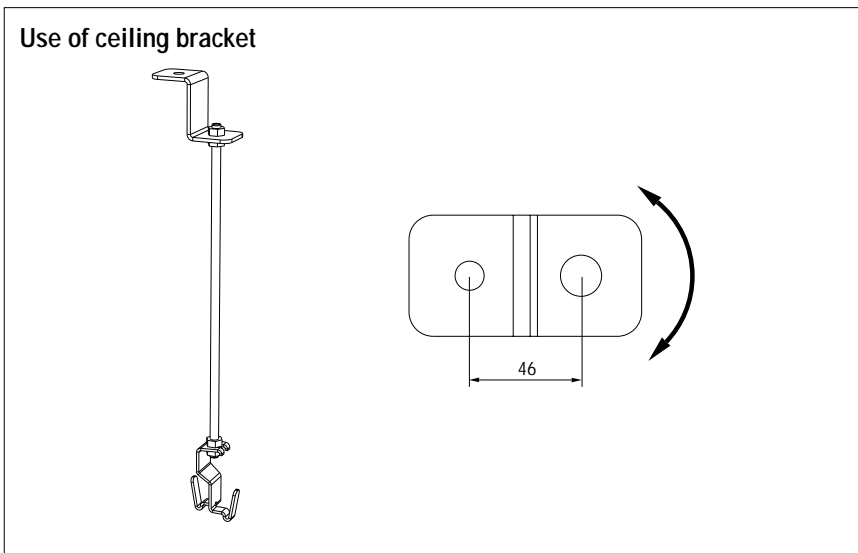

Ceiling bracket RTF-Z is used when fixing to the ceiling cannot be done in exactly the right spot, and threaded rod GT is to be in a vertical position. The adjusting range of ceiling bracket RTF-Z is 92 mm.

Threaded rod GT-10

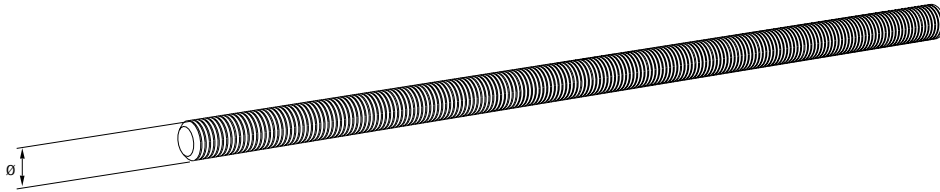

Product	SSTL number	Package m	Weight kg /100 m	Thread	Length m
Zinc electroplated					
GT-10	14 496 50	50	50	M10	2
Hot dip galvanised					
GT-10 ZNK	14 491 60	50	50	M10	2

Installation example

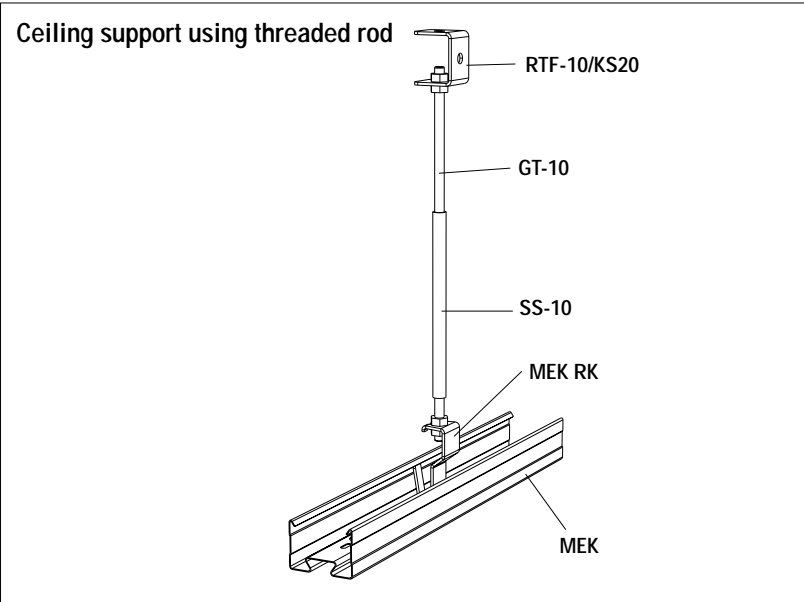

Threaded rod GT-10 or GT-10 ZNK is used in supporting a lighting track from the ceiling. If the threaded rod should be white, protective sheath SS-10 is used to cover the rod.

Protective sheath SS

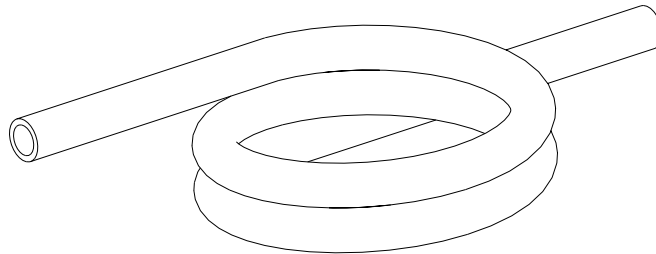

Product	SSTL number	Package m	Weight kg /100 m
---------	-------------	-----------	------------------

Plastic, white

SS-10	14 318 00	100	3
-------	-----------	-----	---

Installation example

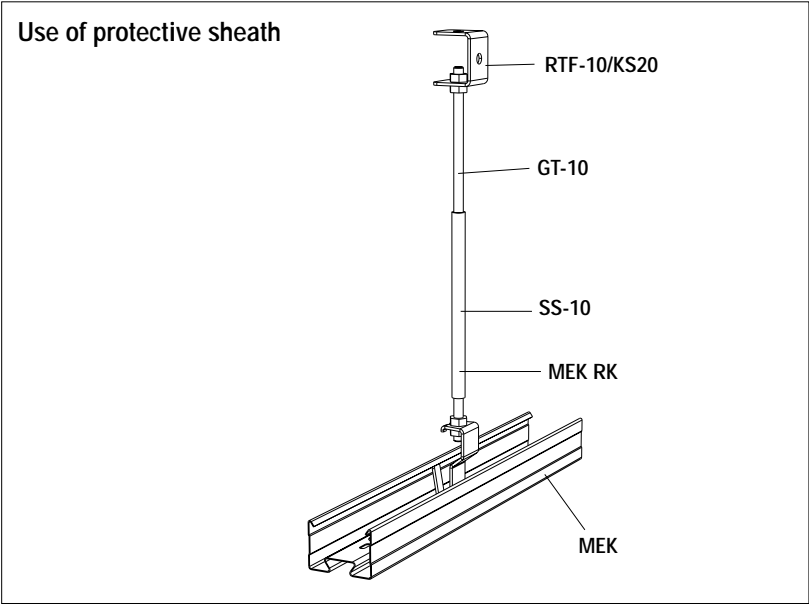

If a threaded rod should be white, protective sheath SS-10 is used to cover the rod.

Touch-up paint MEKA SPRAY

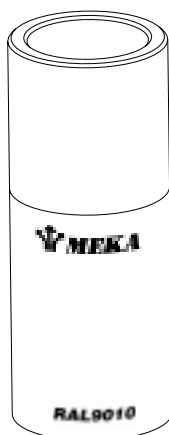

Colour tone RAL 9010
(NCS 0502-Y)

Product	SSTL number	Package pc	Weight kg /100 pcs
MEKA SPRAY RAL 9010	14 318 09	1	19

Installation example

Use of touch-up paint

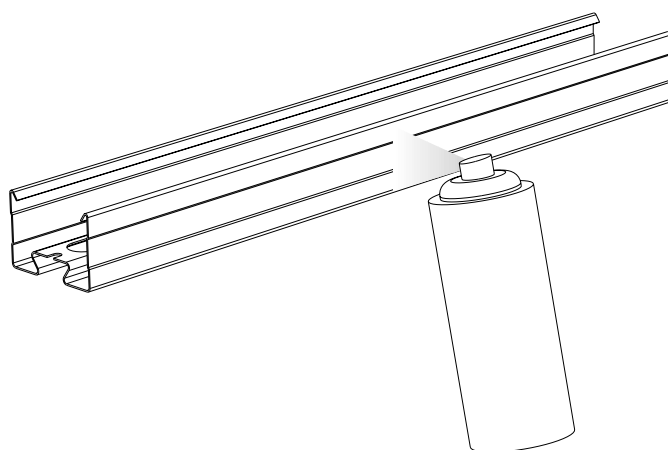

Touch-up paint is used to paint damaged spots. The colour tone of MEKA SPRAY is white RAL 9010.

INSTALLATION ACCESSORIES

End cover MEK P

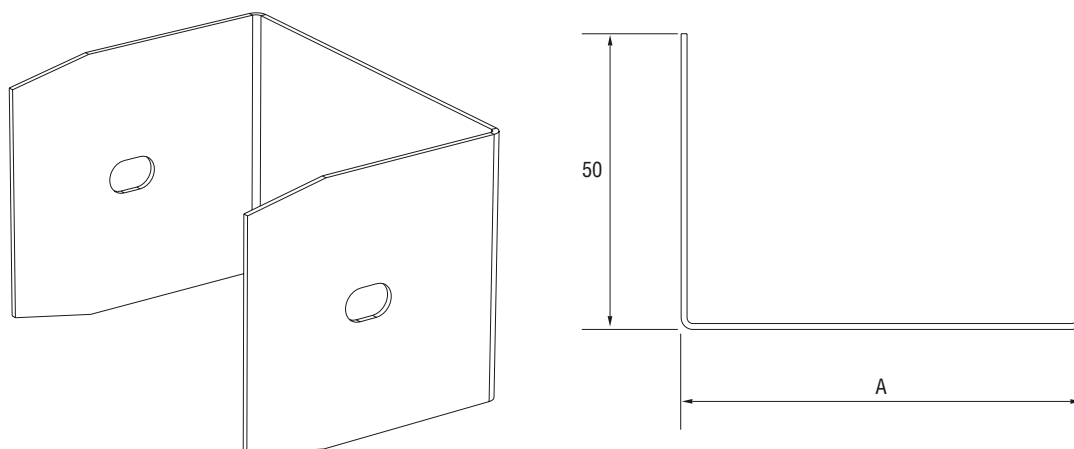

Product	SSTL number	Package pc	Weight kg /100 pcs	A mm
Hot galvanised sheet metal				
MEK P-70	14 493 94	10	7	68
MEK P-110	14 493 98	10	9	108
Hot galvanised and painted sheet metal				
MEK P-70 M	14 493 97	10	7	68
MEK P-110 M	14 494 00	10	9	108

Installation example

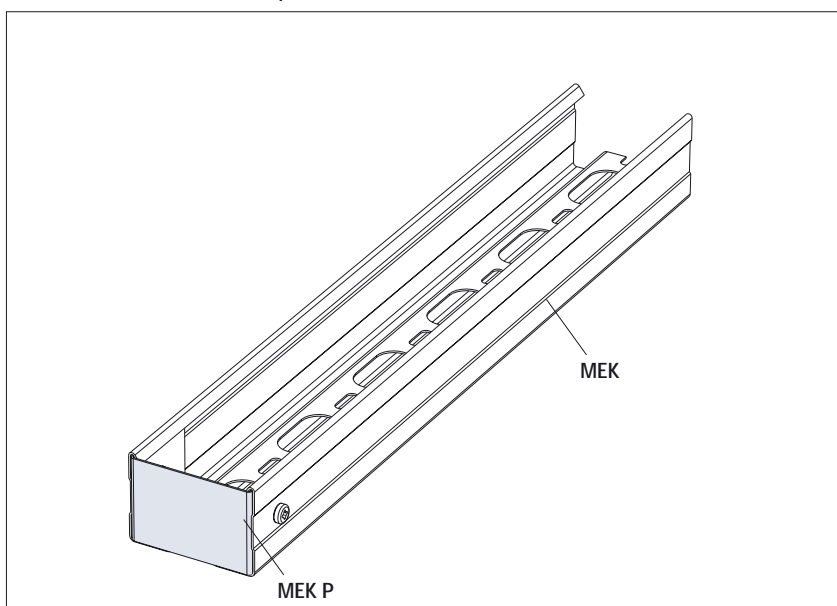

End cover MEK P is fixed by using bolt sets RS MEK J/60.

COVERS

Lighting track cover MEK KA

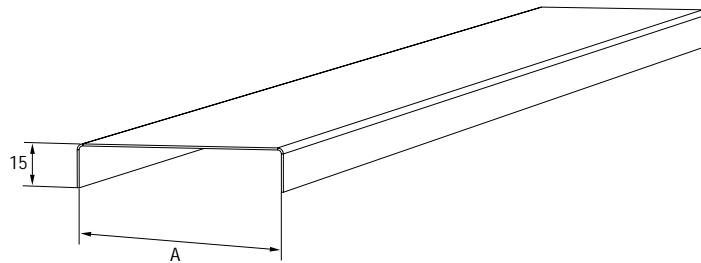

Product	SSTL number	Package m	Weight kg /100 m	A mm	Length m
Hot galvanised sheet metal					
MEK KA-70	14 493 59	30	76	71	3
MEK KA-110	14 493 60	30	105	110	3
White plastic coated sheet metal					
MEK KA-70 M	14 493 39	30	76	71	3
MEK KA-110 M	14 493 40	30	105	110	3

Installation example

Use of lighting track cover

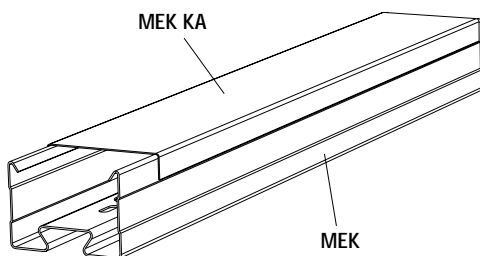

Lighting track cover MEK KA is used to prevent dirt and dust from entering the inside of a lighting track.

Extension nuts JM

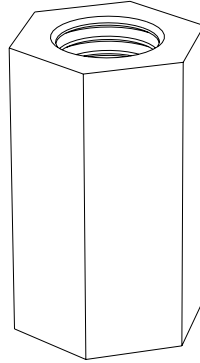

Product	SSTL number	Package pc	Weight kg /100 pcs	Thread
---------	-------------	------------	--------------------	--------

Zinc electroplated

JM M10	14 497 04	100	4	M10
--------	-----------	-----	---	-----

Zinc electroplated and painted

JM M10 M	14 317 46	100	4	M10
----------	-----------	-----	---	-----

Installation example

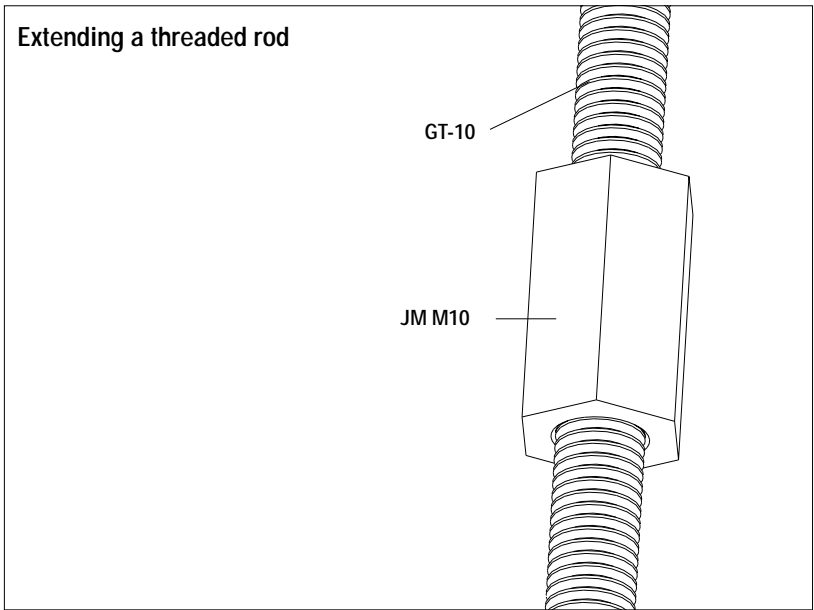

Threaded rod GT can be extended using an extension nut JM.

BOLT SETS

Bolt sets RS

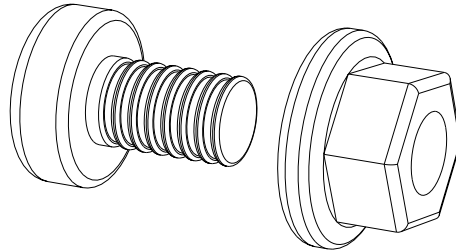

Bolt set RS MEK J

Product	SSTL number	Package pc	Weight kg /100 pcs	Includes
Zinc electroplated				
RS MEK J/10	14 491 08	10	0,47	M5 x 8 cross head bolts + M5 grooved collar nut
RS MEK J/60	14 491 09	60	0,47	M5 x 8 cross head bolts + M5 grooved collar nut
RS MEK VM	14 491 14	100	0,55	M6 x 12 cross head bolts

Nuts MU

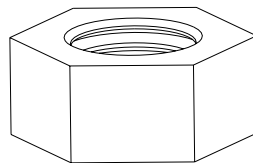

Product	SSTL number	Package pc	Weight kg /100 pcs	Thread
Zinc electroplated				
MU M10	14 499 92	100	1	M10
Zinc electroplated and painted				
MU M10 M	14 317 40	100	1	M10

